

GOLD NOTE
il suono italiano

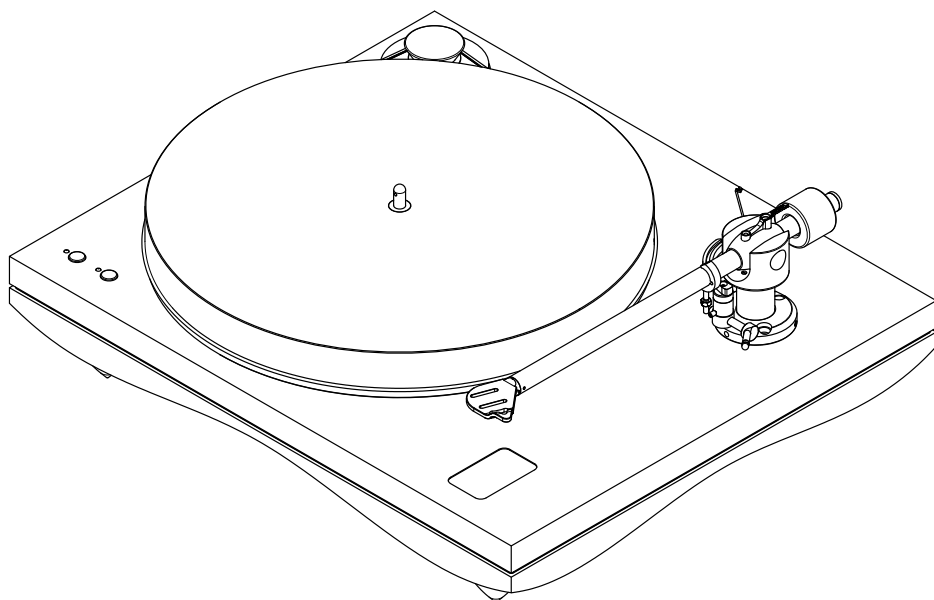

GIGLIO

THE ITALIAN TURNTABLE

USER MANUAL

INDEX

PACKAGE CONTENT.....	P. 3
INTRODUCTION.....	P. 4
KEY FEATURES.....	P. 5
TECHNICAL SPECIFICATION.....	P. 6
SET-UP INSTRUCTION.....	P. 7
INSTALLING THE PLATTER.....	P. 8
INSTALLING THE BELT AND THE TONEARM CABLE.....	P. 10
ANTI-SKATING, COUNTERWEIGHT ADJUSTMENTS.....	P. 11
VTA SETUP.....	P. 12
POWER SUPPLY.....	P. 13
POWER ADAPTER AND SPEED CONTROL.....	P. 14
CALIBRATION: CARTRIDGE OVERHANG, ALIGNMENT AND SPEED.....	P. 15
CARTRIDGE ALIGNMENT.....	P. 16
DETACHABLE DUST COVER.....	P. 17
PRODUCT REGISTRATION.....	P. 18
TROUBLESHOOTING.....	P. 19
IMPORTANT SAFETY INFORMATION.....	P. 20

PACKAGE CONTENT

- 1 Turntable Giglio
- 1 Dust Cover (detachable)
- 1 18V power supply with cable
- 1 B-5.1 tonearm with the cable already installed
- 1 Cylindrical counterweight 110 g
- 1 Additional counterweight 28.5 g
- 1 Drive Belt
- 1 Turntable clamp
- 1 Platter spindle tip to clamp the platter
- 1 Ball-bearing
- 3 Spike washers
- 1 Oil jar
- 1 Felt matt
- 1 Allen key 2,5mm
- 1 Allen key 2,0mm
- 1 Allen key 1,5mm
- 1 Protractor/Overhang for cartridge alignment
with Stroboscope for fine speed adjustments
- 1 GN Stylus Gauge
- 1 User manual

INTRODUCTION

The Giglio follows the beauty and technical innovation of the new generation of turntable designed by Gold Note featuring unique musical qualities and the legacy of strong Tuscan origins.

The Giglio features a 50mm curved plinth made of Italian Walnut, quality materials chosen for their exceptional elasticity, strength and high density, being at the same time evocative of Tuscany landscape, one of the most recognisable places in the world, creating a strong union between the finished product and the skilful local craftsmen who made it by hand.

The curved plinth is precisely cut in the inner side to find the perfect tuning of the wood that is interfaced with a 3mm stainless steel board. The structure is completed with a 20mm thick black polished acrylic top plinth, where the electronic board of the turntable is installed, thus lowering the frequency resonance.

The curved wooden plinth is the result of years of research at the Gold Note engineering labs in order to replace a bigger mass plinth of a more traditional rectangular shape structure; the extra rigidity given by the curves of the plinth allow a sophisticated technical design and a great exclusive look.

The Giglio features a 12V synchronous motor directly derived from Mediterraneo.

Thanks to our proprietary power control generator based on a Quadral-Core micro-controller, Giglio can effectively control vibrations and deliver high torque for the greatest dynamic and resolution.

The Power Supply electronically controls the 33 $\frac{1}{3}$ rpm, the 45rpm modes and the fine speed adjustment storing the selection permanently in memory even when disconnected from the power.

The new perfectly polished hourglass motor pulley also allows the turntable belt to spin smoothly thus reducing the wow&flutter and noise as never before.

The 80mm long platter Spindle/bearing comes directly from the top quality design of the Mediterraneo; it is fully recessed into the acrylic top plinth in order to keep the thick platter as closest as possible to the turntable structure to reduce turbulences generated by the rotation and achieving a virtual zero vibration point.

The platter is 33mm thick made of POM, a very elastic but deaf material, it features an extraordinary ability to reduce vibrations while the high-mass helps the rotational stability.

The platter is designed to operate at only 3mm from the plinth. Such small platter/plinth interference minimise turbulences for the greatest noiseless functionality.

The choice of materials shows a dedication to the native ground that goes beyond the musical dimension of the product to create a truly unique experience.

Every Gold Note product is 100% proudly designed, manufactured and assembled in Italy

KEY FEATURES

CONSTRUCTION FEATURES

This section describes the special features of your Giglio, the construction details, the reasons for the technical choices and the originality of the design.

- The Giglio is a rigid turntable that uses a 50mm thick plinth made of Italian Walnut wood or Gold leaf interfaced with a 3mm stainless steel and a 20mm acrylic plinth.
- The plinth bears three adjustable aluminium feet to ensure high insensitivity to vibrations.
- The turntable platter is 33mm thick and made of Ultra-Dampened POM, a particularly deaf polymer.
- The recessed Spindle allows the platter to spin very close to the turntable plinth in order to reduce the turbulence caused by rotation.
- The spindle is a high quality machined stainless steel piece that clamps the platter with its conical shape named Split-Spindle™, it's 80mm long to ensure a top class performance. A large longitudinal groove is located on its axis to allow the lubricating oil to run constantly. The longer spindle eradicates any pendulum effect and distributes the inertial energy along its entire axis, completely annulling any type of lateral friction.
- The bronze bearing is rectified to guarantee a smooth spindle rotational stability while a customised bottom platter bearing enables very low noise.
- The platter bearing is threaded outside in order to be tightly blocked to the plinth of the turntable on its own axis allowing a precise coupling.
- The custom AC 12V micro-controlled motor allows 33⅓rpm & 45rpm electronic speed control and pitch adjustment. Besides the special motor guarantees a perfect rotation stability and great torque in complete silence.

TECHNICAL SPECIFICATION

MAIN FEATURES

Wow & Flutter: 0,1%

Rumble: -78dB

Speed: 33 $\frac{1}{3}$ rpm and 45rpm \pm 0,1%

Speed: Changing electronic with fine pitch control

Transmission: 70 shores rectified EPDM belt

Motor: high torque 12V synchronous

Platter: 33mm thick high-density POM

Platter Spindle: Split-Spindle™ clamping design

Platter Bearing: Tungsten 5mm ball bearing

Tonearm: Gold Note B-5.1 (or opt. B-7 Ceramic)

Dust Cover: transparent acrylic with hinges

POWER

Power Supply: 18V output

Power Consumption: max 27 W

100-240V / 50-60Hz

DIMENSIONS AND WEIGHT

Dimensions: 425 W x 200 H x 360 D mm

Weight: Kg. 14.5 net – Kg. 20.5 boxed

SET-UP INSTRUCTION

FIRST OPERATION

1. Please remove carefully all the protecting foam and check if all the listed items are supplied.

2. Place the Giglio deck on a levelled surface, such as a wall shelf immune to footfall, then level the turntable.

3. Plug the DIN/RCA cable of the arm on the shaft female connector DIN side, hooking the RCA connectors to the amplifier phono input.

4. Install the counterweight into the rear arm wand of the arm

selecting the correct cartridge tracking weight with the help of a precision scale (not supplied).

5. Install the turntable belt surrounding the hourglass motor pulley and the platter outer perimeter.

6. Plug the Power Adapter cable to the 12V rounded plug Turntable Speed Control and then plug the AC

adapter to the AC plug once selected the right international plug supplied.

POSITIONING THE GIGLIO

Your Giglio has been designed for Hi-Fi systems. It must be protected from direct sun and humidity. Do not place it near heating sources, electrical and electronic motors, mobile phones etc.. The levelling and positioning on a solid shelf, as explained in the previous chapter, is fundamental to ensure the best audio performances.

OPERATING THE 33 $\frac{1}{3}$ rpm & 45rpm CONTROL

The turntable is fully controlled by an electronic power supply.

TURNTABLE SPEED CONTROL ADJUSTMENTS

- Inner button starts and stops the 33 $\frac{1}{3}$ rpm speed.

Once the 33 $\frac{1}{3}$ rpm is playing its red LED light turns on.

- Outer button starts and stops the 45rpm speed.

Once the 45rpm is playing its red LED light will be on.

The Giglio also features a fine speed adjustment “Pitch Control” function to allow a very fine and precise speed calibration.

PITCH CONTROL MODE

To enter the PITCH CONTROL MODE press and hold for 4 seconds both 33 $\frac{1}{3}$ rpm and 45rpm buttons while the turntable is spinning.

When the red LED light shuts down, the unit is ready for the fine speed adjustment.

- PITCH – press repeatedly the 33 $\frac{1}{3}$ rpm button until the correct speed is reached.

The LED light flashes every time the button is pressed.

- PITCH + press repeatedly the 45rpm button until the correct speed is reached.

The LED light flashes every time the button is pressed.

See pag.14 for images.

To switch off of the PITCH CONTROL MODE press and hold for 4 seconds both the 33 $\frac{1}{3}$ rpm and the 45rpm buttons until the LED light is on and steady again.

INSTALLING THE PLATTER

CONTENT OF THE TURNTABLE BOX

- 1 Platter
- 2 Oil Vessel
- 3 Ball bearing
- 4 Platter Spindle Tip + Platter spindle

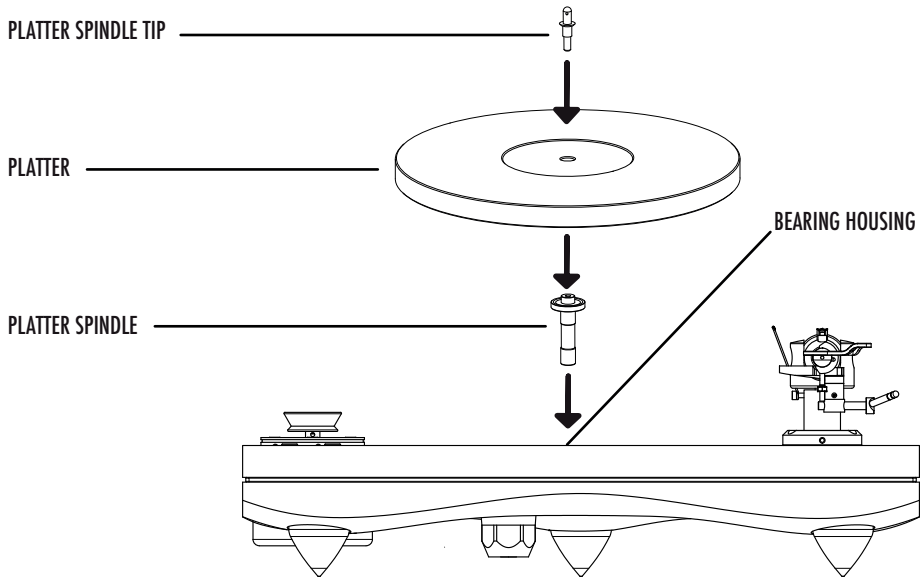
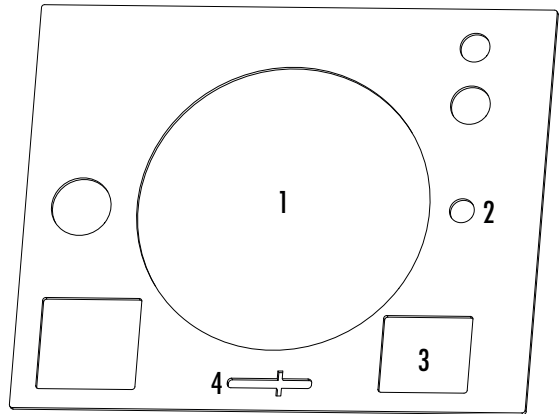

INSTALLING THE PLATTER

INSTRUCTIONS

- 1 Remove plug from the middle of the turntable
- 2 Insert the Ball Bearing into the Bearing Housing* of the turntable taking care to centre it on the bottom seat
- 3 Oil the Platter Spindle as shown in figure 3
- 4 Insert the Platter Spindle into the Bearing Housing
- 5 Lay the Platter on the Platter Spindle
- 6 Secure the Platter Spindle Tip in the threaded hole of the Platter Spindle

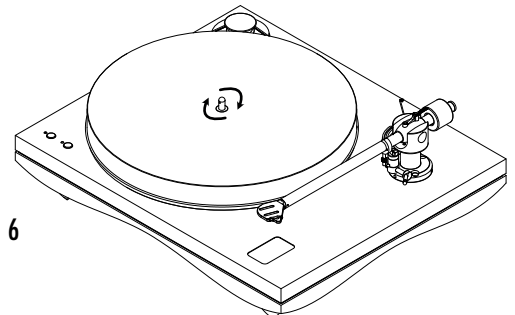
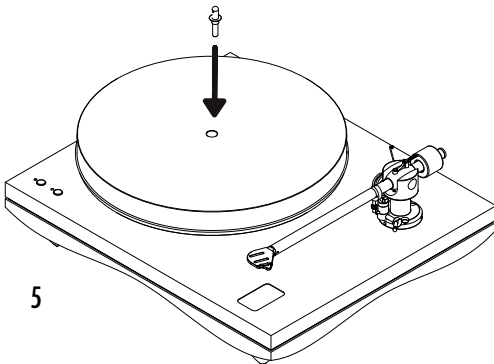
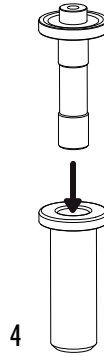
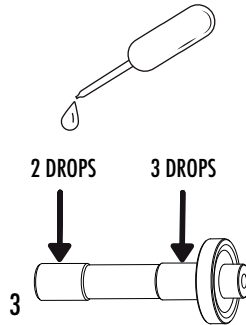
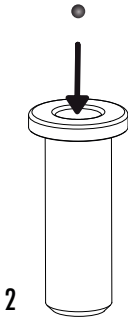
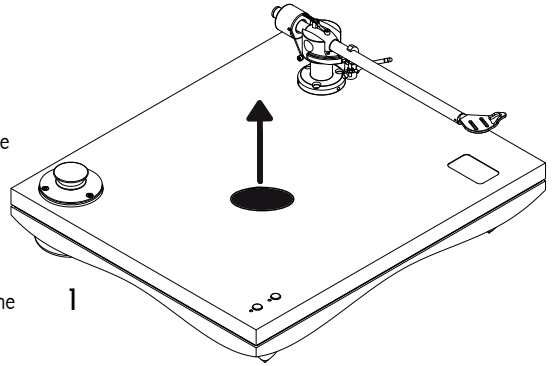

***PLEASE NOTE:** the Bearing Housing is already installed in the plinth of the turntable. Do not remove it.

INSTALLING THE BELT AND THE TONEARM CABLE

Wrap the belt around the pulley and the platter as shown in the picture:

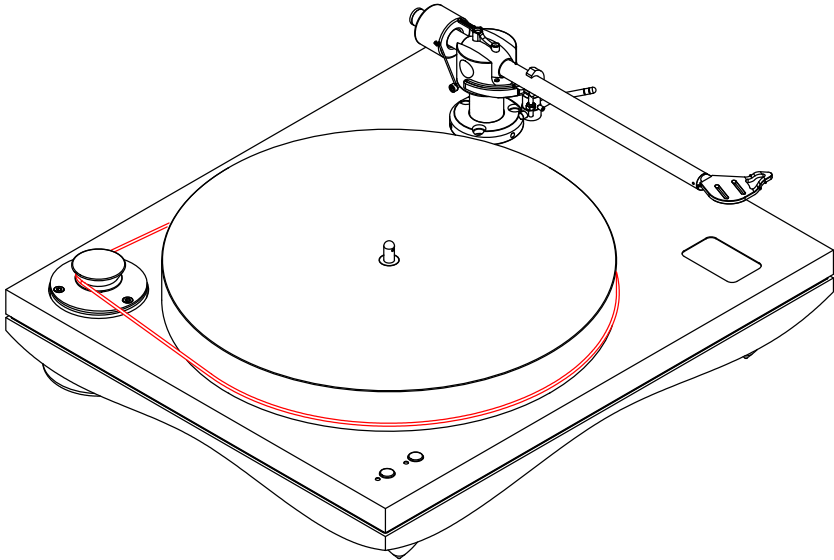

The tonearm cable should be always connected before the tone arm is installed on the turntable.
Always pay attention to the cable and make sure it is connected before placing the tonearm in position.

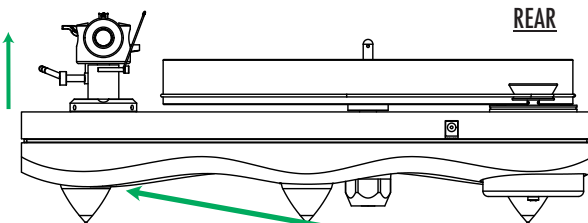

The Male DIN plug and the female DIN plug must be connected as shown in the picture below.

ANTI-SKATING, COUNTERWEIGHT ADJUSTMENTS

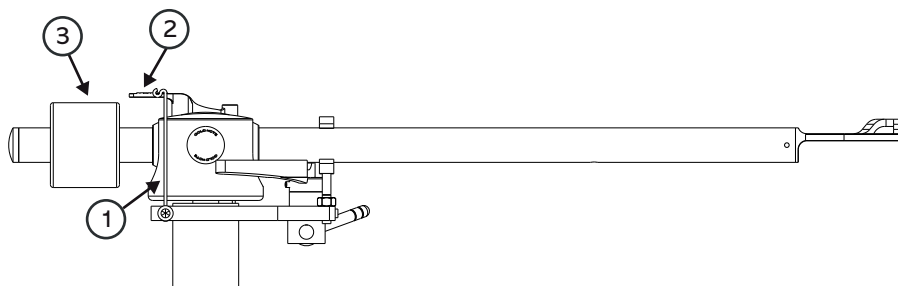

1. ANTI-SKATING nylon wire with bullet counterweight
2. ANTI-SKATING adjustment bar
3. TONEARM COUNTERWEIGHT: to set up the correct tracking force depending on the phono cartridge in use

INSTALLING THE ANTI-SKATING SYSTEM

1. Slip the loop of the ANTI-SKATING nylon wire over the groove of the ADJUSTMENT BAR
2. Feed the wire through the loop of the SUPPORT HOOP
3. Adjust the ANTI-SKATING force choosing the correct groove on the ADJUSTMENT BAR

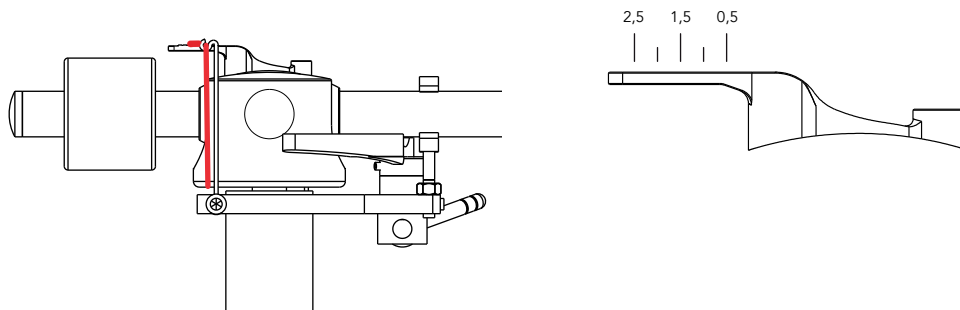

VTA SETUP

VTA SETUP

To up or down the arm by correctly adjusting the VTA, use the 1.5 mm Allen key supplied by Gold Note and insert it in the three holes on the arm board indicated by the arrows.

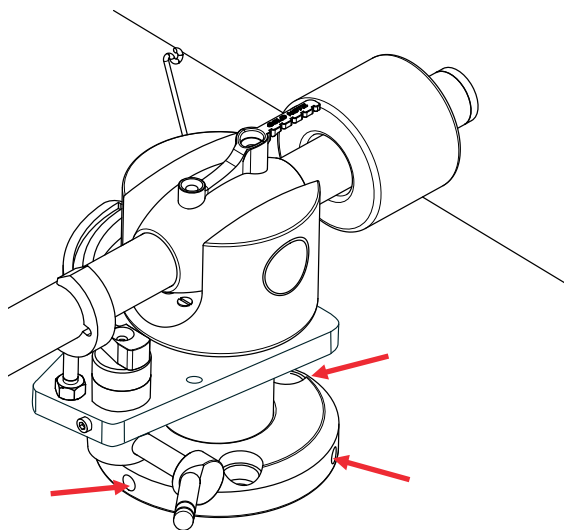
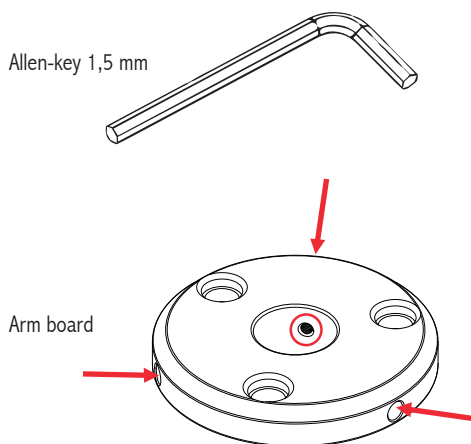

POWER SUPPLY

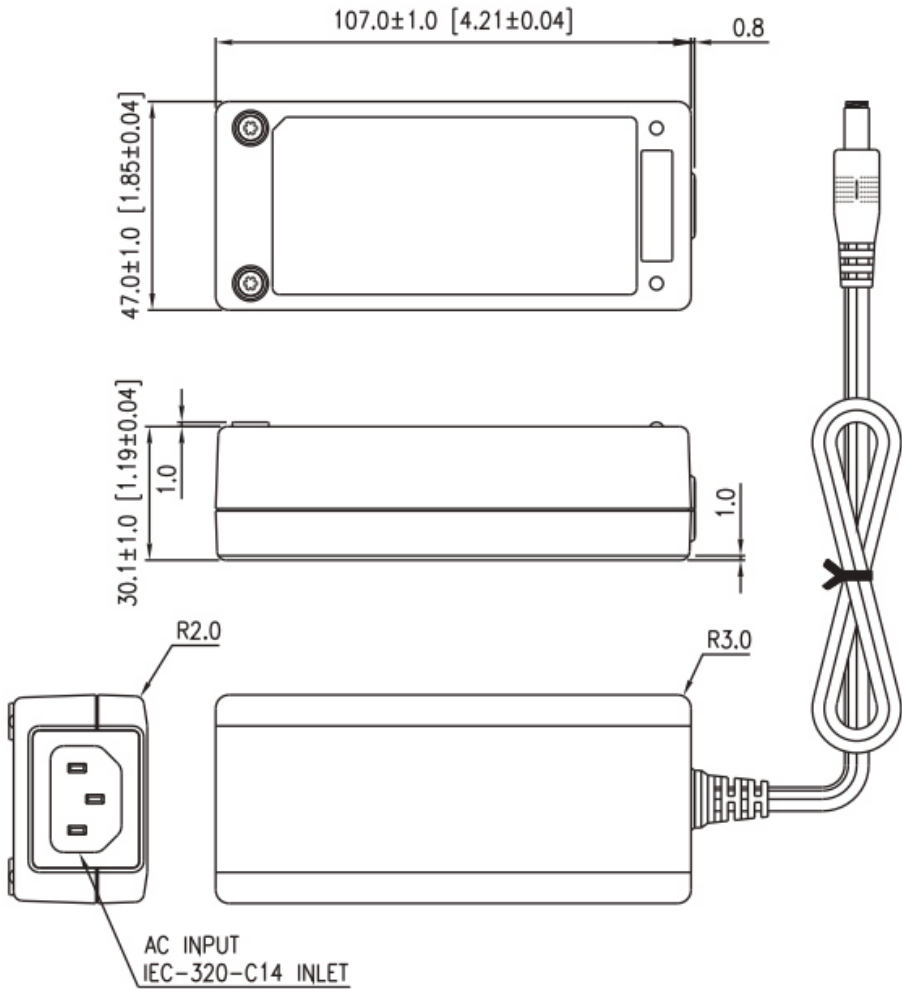

1. Dimensions are shown in mm & inch
2. Weight: approx. 265~280g (exclude the input cord)
3. Optional output connector

4. Operating Temperature: 0 to 70°C
5. Derate linearly from 100% load at 40°C to 50% load at 70°C

PLEASE NOTE: Please with the super power supply PST-1 supplied use only the power cord supplied or one strictly certified for UL, CE, and all local necessary certifications.

POWER ADAPTER AND SPEED CONTROL

CONNECTING THE POWER SUPPLY ADAPTER

Use only the original GOLD NOTE AC adapter to power the turntable to ensure the correct functioning.

PLEASE NOTE: Before plugging the adapter in to the AC make sure the connector is plugged into the turntable.

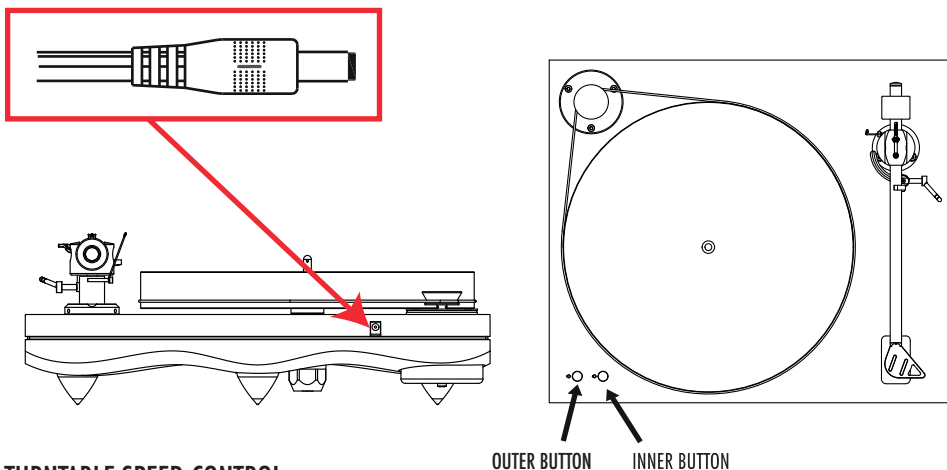

TURNTABLE SPEED CONTROL

- INNER BUTTON starts and stops the 33 $\frac{1}{3}$ rpm speed. When the 33 $\frac{1}{3}$ rpm is playing its red LED light turns on.
- OUTER BUTTON starts and stops the 45rpm speed. When the 45rpm is playing its red LED light turns on.

The Giglio also features a fine speed adjustment “Pitch Control” function to achieve a precise control over the speed of the turntable.

PITCH CONTROL MODE

To enter the PITCH CONTROL MODE press and hold for 4 seconds both the 33 $\frac{1}{3}$ rpm and the 45rpm buttons while the turntable is spinning at 33 $\frac{1}{3}$ rpm or 45rpm until the red LED light shuts down. The unit is now ready to adjust the speed with the help of the stroboscope.

- PITCH – press in sequence the 33 $\frac{1}{3}$ rpm button until the correct speed is reached.

The LED light flashes every time the button is pressed.

- PITCH + press in sequence the 45rpm button until the correct speed is reached.

The LED light flashes every time the button is pressed.

To switch off of the PITCH CONTROL MODE press and hold for 4 seconds both the 33 $\frac{1}{3}$ rpm and the 45rpm buttons until the LED light is on and steady again.

CALIBRATION: CARTRIDGE OVERHANG, ALIGNMENT AND SPEED

Our turntables and tone arms are always supplied with the Gold Note Calibration Tool to calibrate correctly the setup. With this tool you will be able to adjust:

- A) Phono Cartridge alignment
- B) Overhang
- C) 45rpm and 33 1/3rpm speed (requires a strobe light)

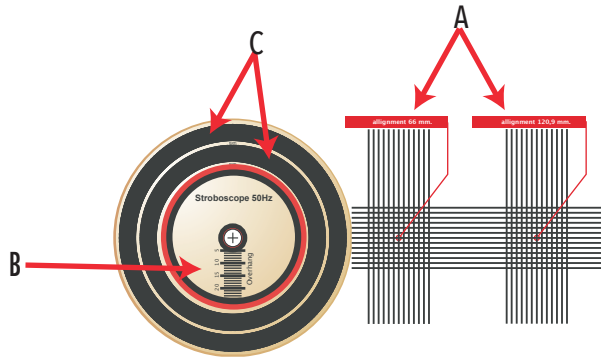

SPEED ADJUSTMENTS

Check the speed with the help of a strobe light (eventually a home NEON can also work).

When the speed is correct you will be able to see the sequence of black rectangular signs as if they were stable and fixed while the platter is spinning.

The outer line is to check the 33 1/3 rpm

The inner line is to check the 45rpm

OVERHANG

To set the correct overhang the Calibration Tool must be inserted on to the turntable record pin and the cartridge Tip must be positioned on top of the pin.

Adjust the position of the cartridge until the suggested overhang of the phono cartridge is reached as indicated by the manufacturer.

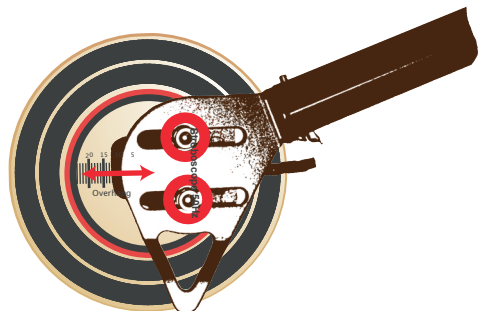
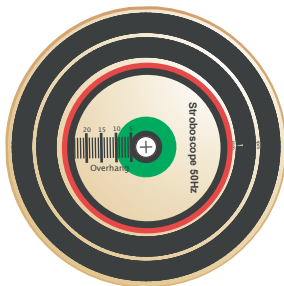

CARTRIDGE ALIGNMENT

PHONO CARTRIDGE ALIGNMENT

To correctly align the phono cartridge and achieve the best tracking position, point the tip of the phono cartridge into the white circles as in the picture below.

The body of the phono cartridge must be aligned to the vertical stripes in order to achieve the best position for musical reproduction.

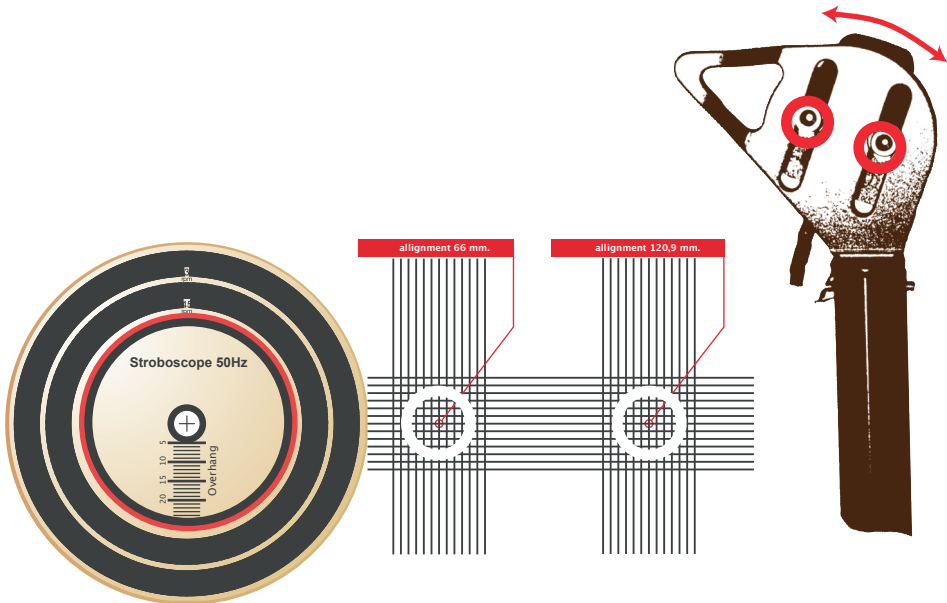

DETACHABLE DUST COVER

The new Gold Note dust cover features detachable hinges, a new proprietary design developed to let you enjoy your turntable at the best in any situation.

The new dust cover is incredibly versatile and allows the usage of the turntable with or without it.

We are proud to offer this new solution to our clients to help them preserve their turntables in ideal functional and cosmetic conditions.

PICTURE 1

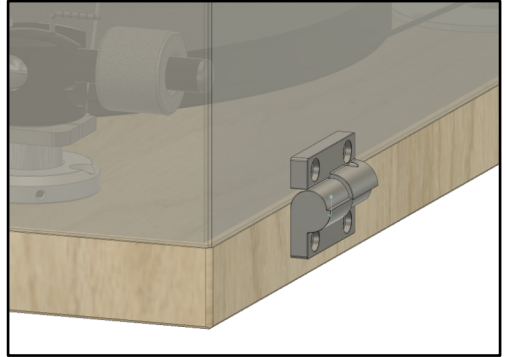

PICTURE 2

The new design also provides a stop point at about 90° to the dust cover: in this position it automatically stops and the hinges will hold the dust cover avoiding overturning.

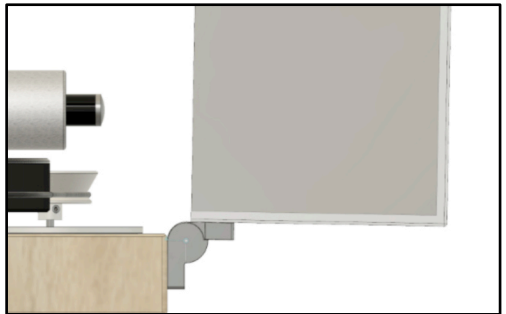

PICTURE 3

Removing the dust cover is simple and quick:

lift the dust cover until it reaches the 90° stop point and it's completely opened, then gently slide it towards LEFT (facing the turntable) to detach it from the plinth.

Please Note: the dust cover can be removed and reinserted only when it's in its resting position, completely opened at 90°.

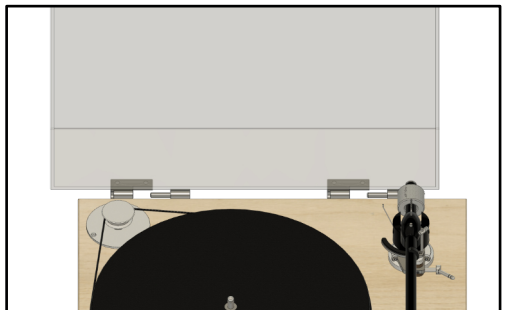

PRODUCT REGISTRATION

PRODUCT REGISTRATION

We recommend to register the unit on our internet website within 15 days from the purchase at

www.goldnote.it/product-registration

If the unit is not registered correctly or has been purchased from a different country of the purchaser home address the unit will not be covered by any warranty and the registration will be refused.

Please note that the warranty does not cover in any case: Tubes, Phono Cartridge Stylus and Batteries.

WARRANTY

All Gold Note products come with a warranty against defective materials and workmanship.

Any service and inspection must be carried out by a Gold Note dealer or distributor so in case you need any assistance with this product, please contact the seller.

If you experience any problems locating your official Gold Note dealer or distributor, please check our website.

PLEASE NOTE

Descriptions and technical characteristics may vary at any time and without notice.

WARNING

Gold Note products should only be opened, serviced and inspected by certified Gold Note technicians and dealers.

Work performed by unqualified personnel may cause serious damage or personal injury. Opening of the product by non-authorised personnel will void the guarantee. In this case, contact your dealer to be advised on how the fault can be solved.

Do not return any object directly to the factory or to the distributor without being authorised to do so.

TROUBLESHOOTING

PROBLEM	CAUSE	SOLUTION
Levelling the turntable	The turntable is not levelled	With a spirit level, only level the Turntable Platter through its shelf layer eventually screwing its feet just for very fine adjustment, take care of levelling the platter on its vertical and horizontal lines. Be sure that the turntable layer is enough solid and rigid to support the weight of the turntable Easily.
Cleaning the turntable	The turntable is dirty and requires cleaning	With EXTREME care use ONLY very soft 100% cotton cloth to sweep dust and stains out. Any acid or not extremely soft cloth will irreversibly damage the turntable fine aesthetic. Do not use any alcohol to clean the turntable anodised label, pulley and motor spindle. Only dry cloth is allowed.
Motor heating	The motor is too hot	AC synchronous motors as the ones used by Gold Note may warm up to 50° Celsius without creating any problem.
Noise on startup	The turntable produces a slight rubbing noise upon startup	It is normal for the belt to produce a slight noise when starting.

For spare parts visit the official Gold Note store at:

www.akamaiaudio.it

IMPORTANT SAFETY INFORMATION



CAUTION
RISK OF ELECTRIC SHOCK
DO NOT OPEN



CAUTION!

TO REDUCE THE RISK OF ELECTRIC SHOCK, DO NOT REMOVE COVER (OR BACK). NO USER-SERVICEABLE PARTS INSIDE. REFER ONLY TO QUALIFIED GOLD NOTE SERVICE PERSONNEL FOR SERVICE



WARNING
FIRE OR SHOCK HAZARD



WARNING!

TO PREVENT FIRE OR SHOCK HAZARD, DO NOT EXPOSE THIS APPLIANCE TO RAIN OR MOISTURE

Do not disassemble any part of the product.

Do not use any part of the product for other purposes.

For service and problems of any kind, contact qualified Gold Note personnel.

Protect the product from rain and humidity and keep away from heat sources, electric and electronic motors etc.

The power Chord supplied must be used only on this unit.

Gold Note does not have responsibility for any improper use of this unit.

This appliance has a serial number located on the rear panel.

Please record the model and serial number and retain them for your records.

Serial Number: _____

Model: _____

IMPORTANT SAFETY INFORMATION

1. Follow the instructions and store them
2. Heed all warnings
3. Do not use this apparatus near water
4. Clean only with a dry cloth
5. Do not install near heat sources such as radiators, heat registers, stoves or other apparatus
6. Do not defeat the safety purpose of the polarised or grounding-type plug: a polarised plug has two blades with one wider than the other.

A grounding type plug has two blades and a third grounding prong.

The wide blade or the third prong are provided for your safety.

If the provided plug does not fit into your outlet, consult an electrician for replacement of the obsolete outlet.

7. Protect the power cord from being walked on or pinched particularly at plugs, convenience receptacles, and the point where they exit from the apparatus.

8. Only use attachments/accessories specified by the manufacturer.

9. Use only with the cart, stand, tripod, bracket, or table specified by the manufacturer, or sold with the apparatus.

When a cart is used, use caution when moving the cart/apparatus combination to avoid injury from tip-over.

10. Unplug this apparatus during lightning storms or when unused for long periods of time.

11. Refer all servicing to qualified service personnel only.

Servicing is required when the apparatus has been damaged in any way (such as when the power cord or plug is damaged, liquid has been spilled or objects have fallen into the apparatus, the apparatus has been exposed to rain or moisture) and in any case when the apparatus does not operate normally or has been dropped.



 [goldnote_italy](https://www.instagram.com/goldnote_italy)

 [Gold Note Audio](https://www.facebook.com/GoldNoteAudio)

 [Gold Note](https://www.youtube.com/GoldNote)

Akamai S.r.l.
service@goldnote.it
www.goldnote.it