

GOLD NOTE

il suono italiano

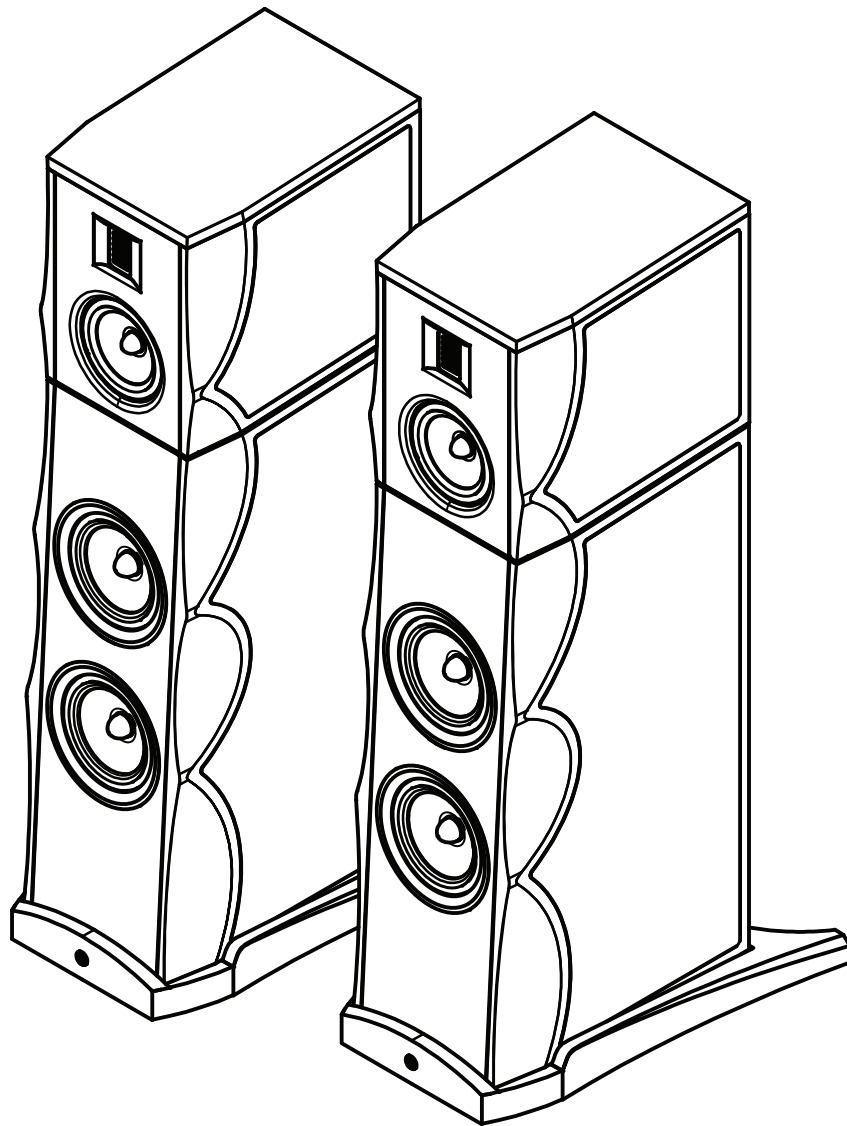

XT-7

XT-7 FULL RANGE 3 WAY SPEAKER

INDEX

| | |
|---|-------|
| PACKAGE CONTENT..... | P. 3 |
| DESCRIPTION..... | P. 4 |
| TECHNICAL SPECIFICATIONS..... | P. 6 |
| UNBOXING THE SPEAKER AND MOUNTING THE FOOT..... | P. 7 |
| CONNECTING THE SPEAKERS..... | P. 9 |
| SPEAKER POSITIONING..... | P. 11 |
| PRODUCT REGISTRATION..... | P. 16 |
| FAQ AND TROUBLESHOOTING..... | P. 17 |
| IMPORTANT SAFETY INFORMATION..... | P. 18 |

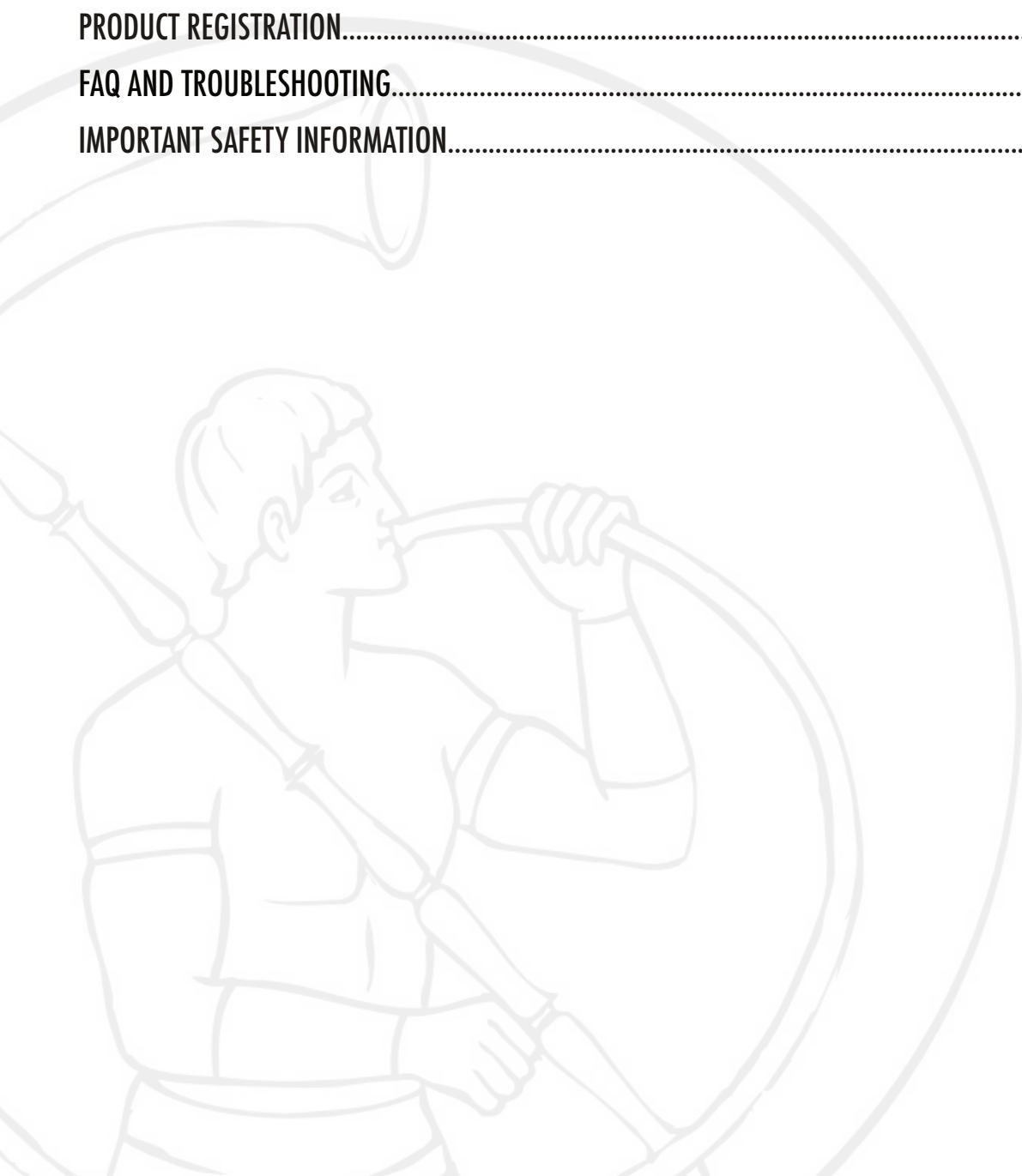

PACKAGE CONTENT

- 2 XT-7 Loudspeakers
- 2 Loudspeakers covers
- 12 Allen screws M4X40
- 12 Washer M4
- 8 Spike XT-7 8 Spike sandblasted + black blackening
- 1 User Manual

DESCRIPTION

XT-7 FULL RANGE, 3 WAY SPEAKER WITH ANTI-TURBULENCE REAR BASS REFLEX AND RIBBON TWEETER

The unique XT curved design is based on a reinforced cabinet in wooden multilayer panels to control resonances and sound, a design where every single element is crucial and serve the sole purpose of achieving the best sound.

The cabinets are conveniently separated for bass and mid/highs to enhance perfect tuning: the bass drivers cabinet side is vented while the mid/highs is perfectly sealed to reduce internal reflections. The massive swallow tailed stand features adjustable spikes and guarantees perfect stability while completing the structure to enhance performances, the hidden spikes can be adjusted to find always the right balance.

XT-7 offers state-of-the-art solutions for a sound without compromises: high quality crossover exclusively made with all Mundorf and Clarity components and ultra-stiff woven polypropylene SEAS and AMT Ribbon drivers made in Germany.

TWEETER

The first Gold Note loudspeaker to feature a ribbon tweeter, this AMT ultra-linear unit is enhanced with a metal damped rear chamber. With a new custom cooling coil radiator and damping aluminium blocking bar designed for resonance reduction and to increase extension linearity.

MIDRANGES

A 160mm ultra-linear recessed driver developed with SEAS and enhanced with a proprietary metal chassis.

The unique curved cone in ultra-hardened woven polypropylene allows an excellent internal damping factor while the moving parts are perfectly matched together for a smooth and extended frequency response.

A special radial reinforced low loss rubber surround reduces radial resonances and prevents surround break up at large excursions.

The custom aluminium phase plug reduces compression due to temperature variations in the voice coil, avoiding the resonance that would occur between the dust cap and the pole piece while also increasing the long-term power handling capacity. The internal ring around the coil drastically reduces distortion and inter-modulation.

The basket, obtained by MIM (metal injection molding) to achieve extreme stiffness and stability, keeps all the components in perfect alignment.

Large windows above and below the basket's spider are designed to reduce sound reflection, air flow noise and cavity resonance to the minimum; the custom spider enhances driver's excursion and give better details and greater linearity.

DESCRIPTION

WOOFERS

Using the same principles applied to Midranges, we developed with SEAS two 180mm ultra-linear recessed drivers.

The driver is powered by our unique curved cone in ultra-hardened woven polypropylene to achieve great internal damping and perfect control over the moving parts, that are always perfectly matched to deliver a fantastic frequency response.

To allow extreme coil excursion with low distortion, the magnet system features a bumped back plate with long and light weight copper clad aluminium voice coils. The heavy copper ring below the T-shaped pole piece reduces non-linear and modulation distortion.

Bullet shaped phase plugs reduce compression due to temperature variations in the voice coils, preventing any resonance problem that could occur and also increasing the long-term power handling capacity.

The basket obtained with MIM and the basket's spider design are developed to preserve structural alignment for maximum stiffness and also to reduce unwanted noises from air flows, resonance and sound reflection.

CROSSOVER

For XT-7 we developed a deluxe crossover with state-of-the-art components all exclusively provided by Mundorf and Clarity: the passive Crossover Low-High Dual-Slope cuts at 280Hz & 3000Hz and features a resistive design to enable ultra-linear load that support the work of the amplifiers minimising the stress on power supplies even at a nominal impedance of 4Ω.

The boards are made of thick audio-grade and anti-resonance glass fibre with 4 oz gold plated conductors and power a sophisticated triple crossover network and a summing midrange multi-slope design perfectly integrate the drivers of the array for a fulfilling close field audio experience. This high quality crossover is completed with Mundorf handmade air winding coils and Clarity & Mundorf caps.

TECHNICAL SPECIFICATIONS

SPECIFICATIONS

Frequency Response: 35-30000 Hz

Sensitivity: 89dB SPL 2,83V/1m

Nominal Impedance: 4Ω semi-resistive

Tweeter: Ribbon AMT

Midrange: 1x 6" custom GN made by SEAS woven polypropylene

Woofers: 2x 6,5" custom GN made by SEAS woven polypropylene

Crossover: 200Hz and 2200Hz @ 12dB/Oct.

Suggested Power Amplifier: min. 30W

Max Power Handling: 200W RMS

DIMENSIONS AND WEIGHT

Dimensions: 365mm W x 1110mm H x 525mm D

Weight: Kg. 100/pr net - Kg. 120/pr. boxed

UNBOXING THE SPEAKER AND MOUNTING THE FOOT

Place the Woofer carton box as shown below.

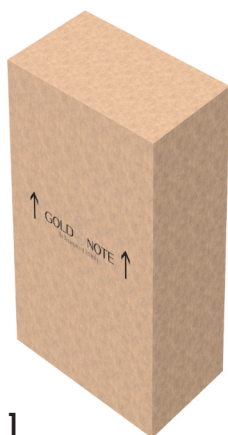

PIC. 1

Open the Woofer carton box from the top.



PIC. 2

Gently turn upside down the Woofer carton box as shown in the picture. Pay attention to the flaps that must be as shown in PIC. 4

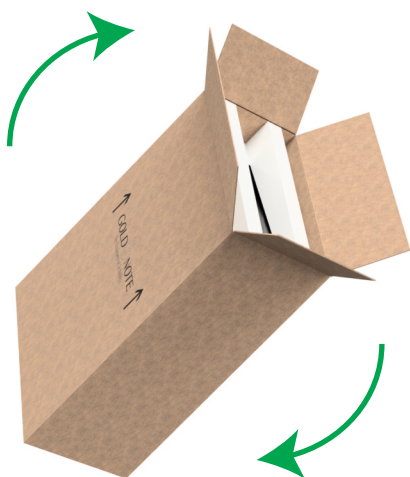

PIC. 3



PIC. 4

UNBOXING THE SPEAKER AND MOUNTING THE FOOT

Should now be upside down. After the bottom protection is removed, you can go to **PIC. 6** being ready to assemble the foot to the Woofer cabinet.

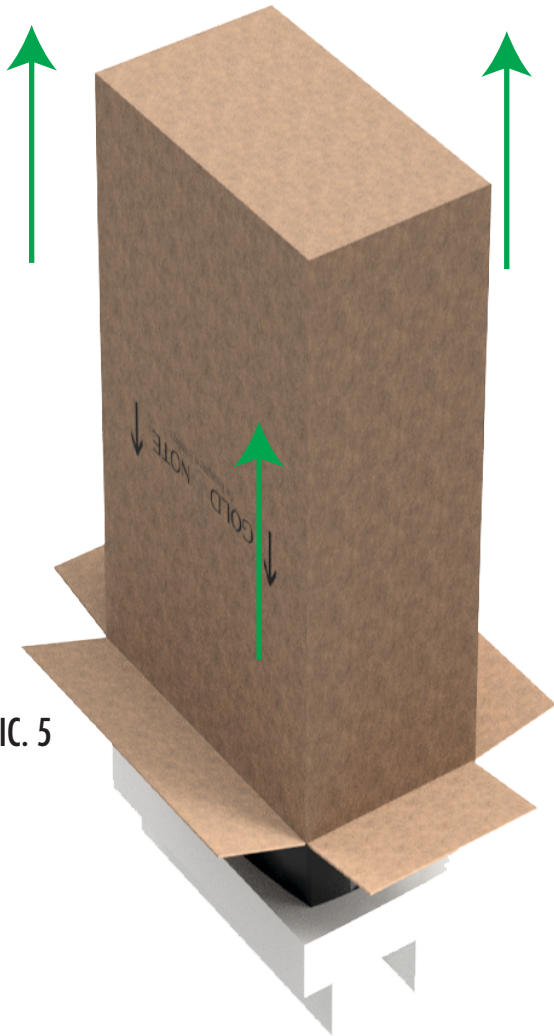

PIC. 5

Take the foot as shown in the picture and use the guides to correctly position the foot on the Woofer cabinet.

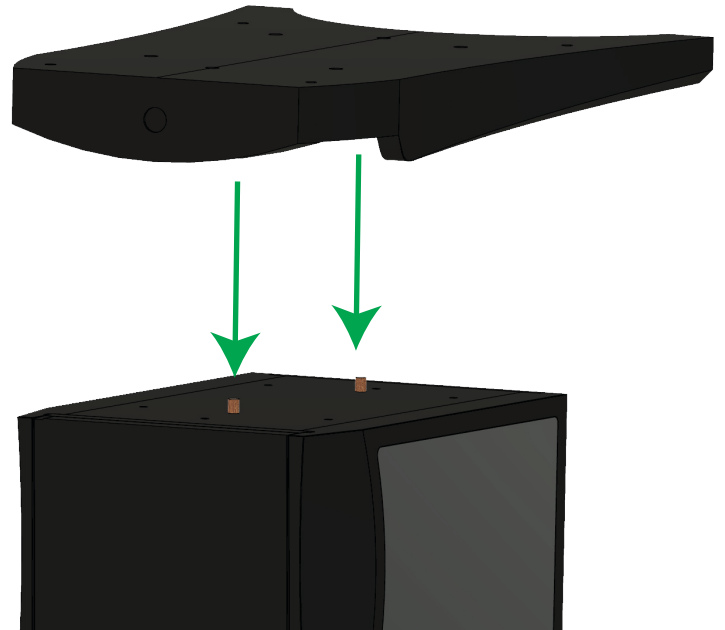

PIC. 6

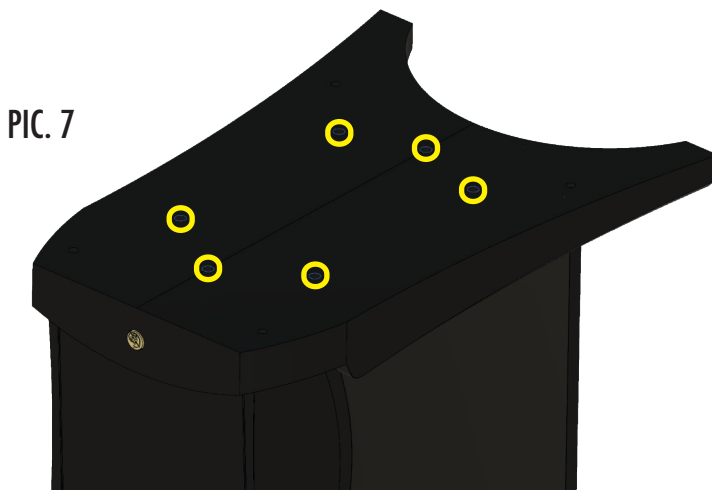

PIC. 7

Allen key

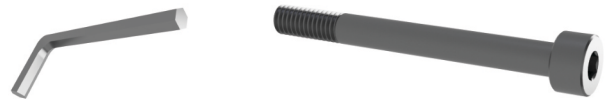

Secure the foot to the Cabinet with 6 screws as shown in picture with the allen key supplied.

ONCE THE FOOT IS ASSEMBLED, PAY EXTREME CARE IN TURNING THE CABINET FACE DOWN. MAKE SURE TO PROTECT IT WITH SOME SOFT MATERIAL TO AVOID DAMAGING THE SURFACES.

CONNECTING THE SPEAKERS

EXAMPLE CONNECTION N. 1

Standard wiring connection (No Bi-Wiring).

Gold Note speakers are all supplied with standard bridge.

Special Exotic Bridge parts of the SIENA BRIDGE ENHANCER line are available on demand

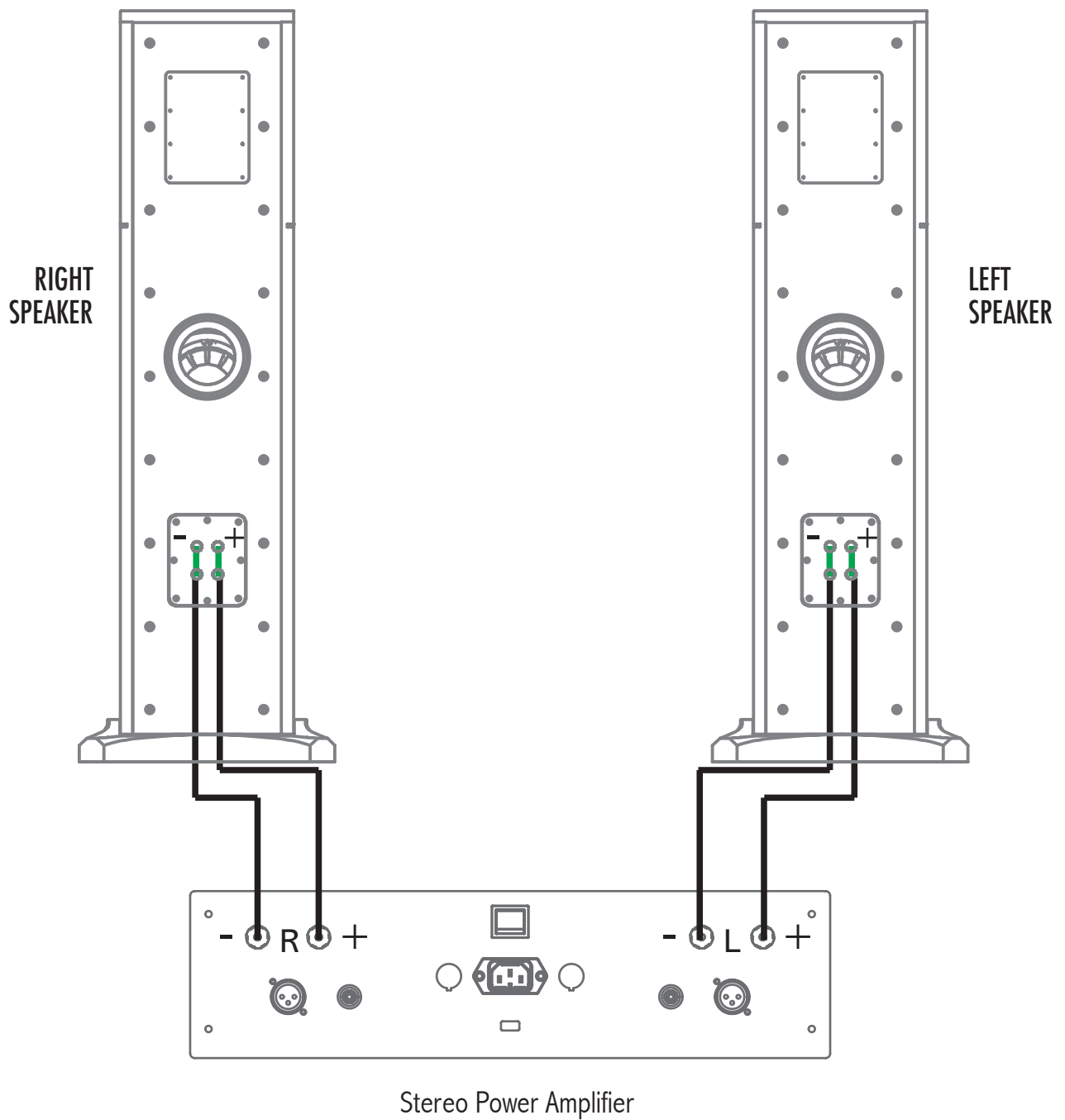

CONNECTING THE SPEAKERS

EXAMPLE CONNECTION N. 2

Bi-Wiring Connection

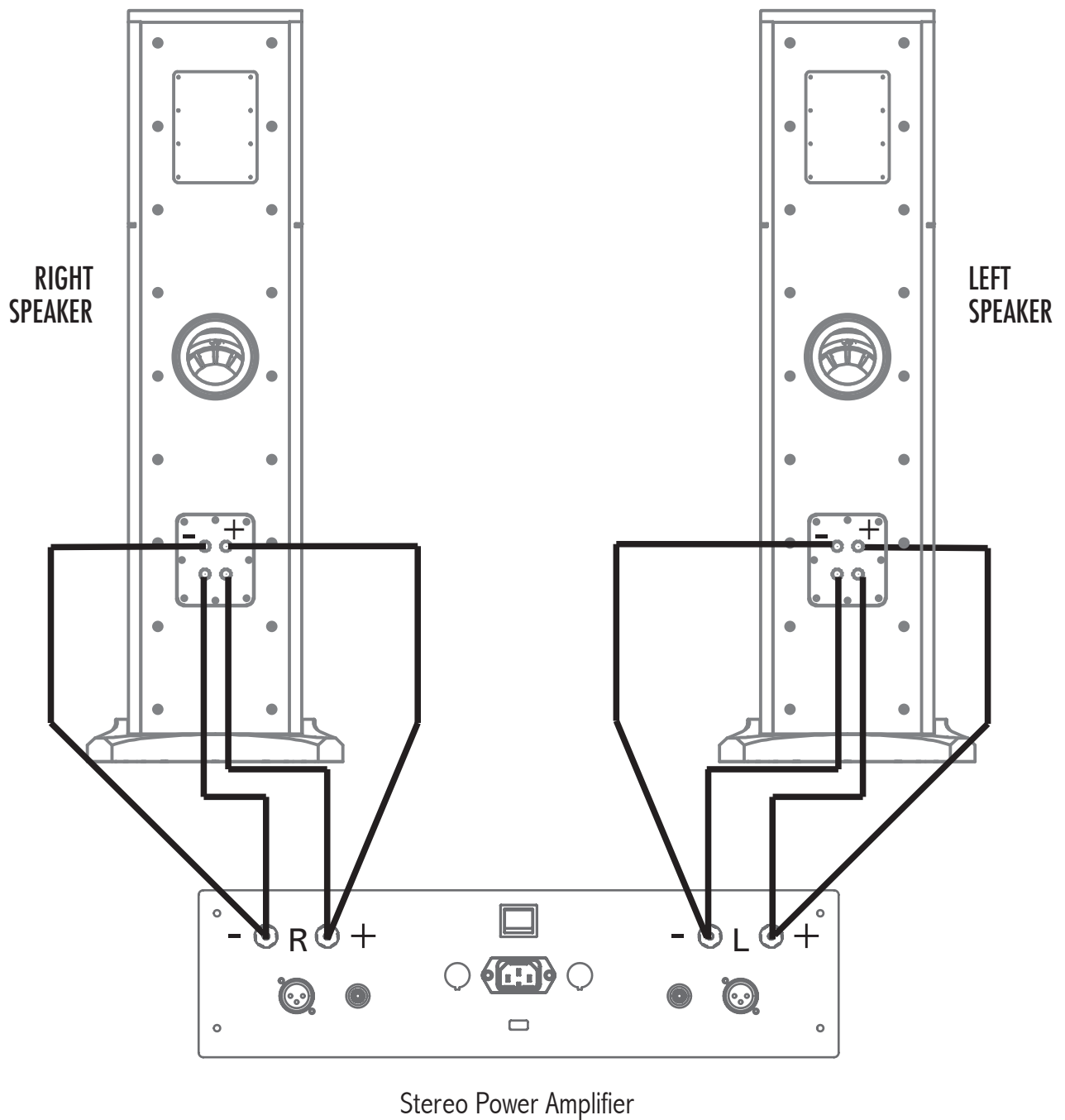

SPEAKER POSITIONING

Identifying the ideal sound/acoustic room to play an audio system well is not that strictly related to the proportional dimensions of the rooms as many audiophiles believe. The sound played through an audio system is just “Energy diffused in a closed environment” that is all absorbed, reflected and dispersed. The loudspeaker position is the most important aspect because managing the reflections is a key factor to get the best sound. The first two reflections are crucial, after them the energy of the reflection starts being lower and does not particularly affect the sound performance.

The first reflection creates a 25m/s delay. Such delay is not favorable because it creates a disturb overwhelming the sound while the delay in between 40 and 80m/s creates what is called ambience.

Therefore it is very important to reduce the first reflection keeping the speaker as far as possible from the side walls and using some carpets on the floor in front of them is advisable.

A symmetrical position of the speakers in the room, having the same distance from the side and rear walls is also very important and should be implemented when possible. The better the positioning the better the focus and the sound stage will be.

WALL MATERIAL

Generally, most of the walls are thick therefore there is the best bass extension control as well as good acoustic isolation. Dry walls vibrate quite a bit, therefore they are usually not favorable or should be treated accordingly.

CEILING

The higher the better. The ideal works between 250 and 360cm having the same regular height.

The vaulted ceiling is quite critical because it works like a magnifier lens increasing the power in specific areas. In case of an attic where typically the ceiling slopes down it is better to position the speakers closer to the lower ceiling and place the listening point in the higher ceiling area.

FLOOR

Marble floors are the worst because they are extremely reflecting but even the all carpet floors don't work well because they absorb indiscriminately. The best option are wooden floors. In any case, all floors can be easily corrected with a 2/4cm thick carpet placed in front of the speakers.

SIDE WALLS

Covering the side walls with a carpet is wrong but leaving them naked is not the ideal solution either. Pictures with frames on the walls are ok if they come without glass protection and are placed symmetrically on both sides of the speakers. Eventually some small specific traps could be a good solutions.

SPEAKER POSITIONING

REAR WALL

The rear wall does not need to be symmetrical like the side walls but some additional acoustic treatment will be able to diffract the energy of the sound wave which is important to get good results.

A traditional library with books and records is a very good “no cost” solution.

OPPOSITE WALL

The wall opposite of the stereo system is not that critical. If it is too close to the listening point itself it would be better covering it with some absorbing material or with a thick curtain.

WINDOWS AND DOORS

They always vibrate. It would be better to not have them situated in the room's corners or in the middle of the side walls. Treating them with absorbing material could be good but they also must be well closed not waving. Having a door behind the listening point could work fine once opened.

Curtains in front of the windows should be light to avoid stopping too much energy, except for the optional ones behind the listening point.

FURNITURE

Ideally, avoid using big furniture with glass/many doors. Open shelf furniture is the best.

If possible, avoid placing the table in between the speakers and the listening point because tables tend to reflect heavily the high and mid-frequencies.

AUDIO RACKS

Though the best position of audio racks usually is not in the middle of the speakers, some special racks such like the Gold Note Galileo can be placed there because its special all curved shape helps diffracting the sound waves very well. If you are using standard racks placed in the middle of the speakers, it is preferable to have rather small ones which enhance a better sound focus.

SUBWOOFER

A general thinking believes the subwoofer does not have any direct emission of sound so the position is not important. In fact, the energy of the waves generated by the subwoofer creates a sound stage which follows rules similar to the full range speakers therefore the same rules should be applied to it as well.

SPEAKER POSITIONING

WIDER STEREO SOUND STAGE SPEAKER POSITION

(for some kind of instrumental music, symphonic orchestra, etc.)

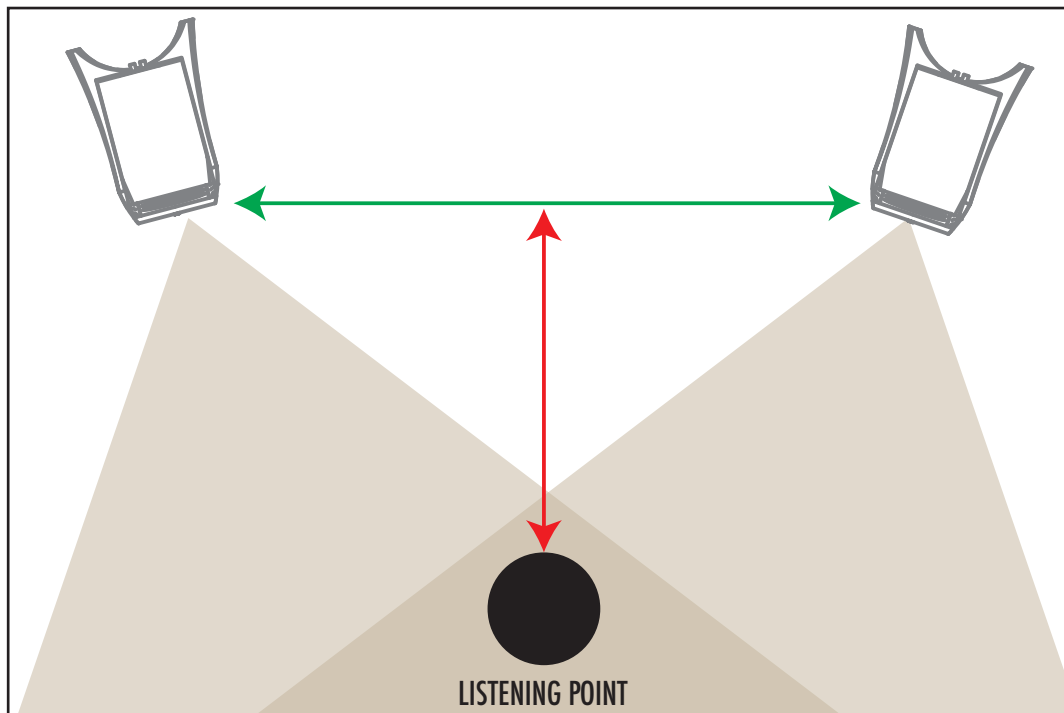

- The distance of both the speakers to the listening point should be the same
- The distance between both the speakers and the side walls should be the same
- The distance between both the speakers and the rear wall should be the same

The more distance there is between the speakers the wider the sound stage will get but less focus will be obtained. To balance the focus, the speakers can be directed to the listening point as indicated in the images of the pages 9 and 10 of this manual.

SPEAKER POSITIONING

NARROWER STEREO SOUND STAGE SPEAKER POSITION

(Optionally for solo instrument music like piano, guitar and voice etc.)

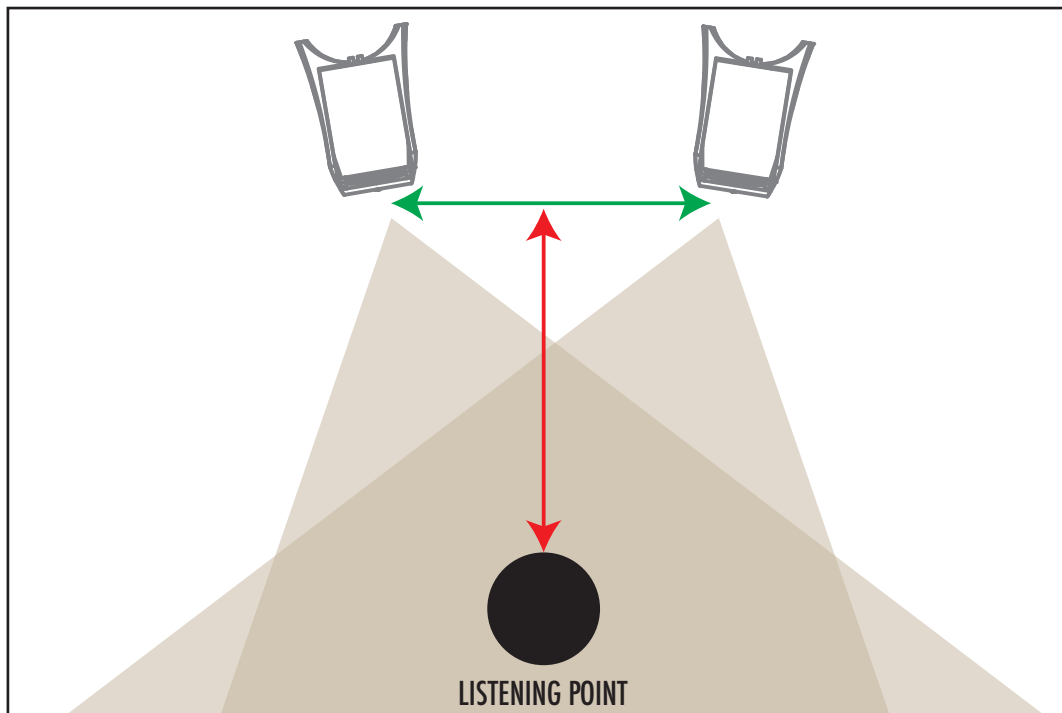

The closer the two speakers stand the better the focus but worse the wide realistic sound stage.

SPEAKER POSITIONING

DISTANCE BETWEEN SPEAKER AND LISTENING POINT ORIENTATION

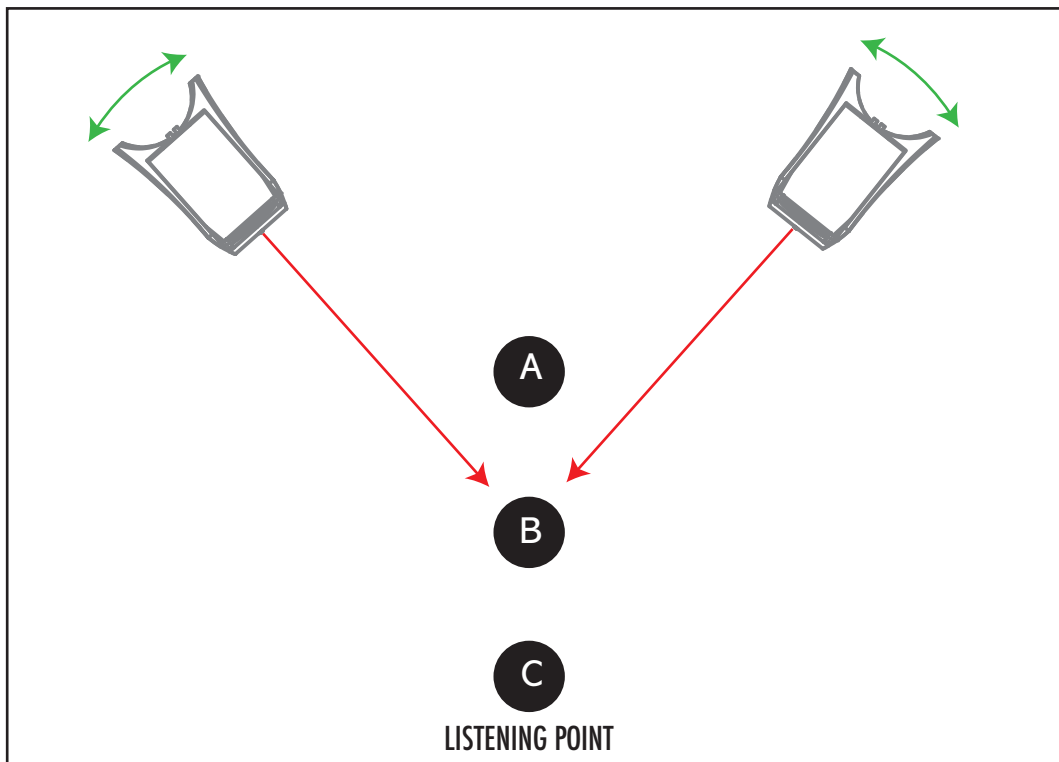

The distance between the speakers should be the same as the one to the listening point. If the distance is shorter, the speaker must be directed to the listening point accordingly (see illustration above).

Empirical tests are necessary to find the right proportion between wide stereo sound stage focus and crispy details.

PRODUCT REGISTRATION

PRODUCT REGISTRATION

We recommend to register the unit on our internet website within 15 days from the purchase at www.goldnote.it/product-registration

If the unit is not registered correctly or has been purchased from a different country of the purchaser home address the unit will not be covered by any warranty and the registration will be refused.

Please note that the warranty does not cover in any case: Tubes, Phono Cartridge Stylus and Batteries.

WARRANTY

All Gold Note products come with a warranty against defective materials and workmanship.

Any service and inspection must be carried out by a Gold Note dealer or distributor so in case you need any assistance with this product, please contact the seller.

If you experience any problems locating your official Gold Note dealer or distributor, please check our website.

PLEASE NOTE

Descriptions and technical characteristics may vary at any time and without notice.

WARNING

Gold Note products should only be opened, serviced and inspected by certified Gold Note technicians and dealers.

Work performed by unqualified personnel may cause serious damage or personal injury. Opening of the product by non-authorized personnel will void the guarantee. In this case, contact your dealer to be advised on how the fault can be solved.

Do not return any object directly to the factory or to the distributor without being authorised to do so.

FAQ AND TROUBLESHOOTING

FAQ

| ACTION | DESCRIPTION | HOW TO ADJUST IT |
|-------------------|---|--|
| CLEANING THE UNIT | <ul style="list-style-type: none"> The Unit is dirty and needs to be cleaned | <ul style="list-style-type: none"> With EXTREME care use ONLY diluted alcohol and a very soft 100% cotton cloth to sweep dust and stains out. Any acid or not extremely soft cloth will irreversibly damage the amplifier fine aesthetic. Do not use any alcohol to clean the unit anodised label, or printed parts. Only dry cloth is allowed. |

TROUBLESHOOTING

| SYMPTOM | DESCRIPTION | CAUSE | REMEDY |
|--------------------------|---|--|---|
| SPEAKER HUMMING PROBLEMS | The speakers hum when the amplifier is connected to the System. | <ul style="list-style-type: none"> The unit is correctly coupled with the Ground on DC. | <ul style="list-style-type: none"> Be sure your area and personal environment are well grounded. Eventually isolate the ground Pin of the power chord plug for verification. |
| | | <ul style="list-style-type: none"> The interconnect input and/or output cables are not shielded. | <ul style="list-style-type: none"> Be sure to always use shielded cables for the amp connections. |
| OUT of PHASE | The sound does not have a proper focus even when well positioned. | <ul style="list-style-type: none"> The speaker terminals (negative/positive poles) are inverted in some way on the amp or on the speaker. | <ul style="list-style-type: none"> Turn Off the amplifier first and then rewire the speaker terminals correctly. |
| SOME DRIVERS DO NOT WORK | | <ul style="list-style-type: none"> The bridges are not well connected to the speaker terminal (Binding Posts). | <ul style="list-style-type: none"> Connect the bridges properly. |
| | | <ul style="list-style-type: none"> The speaker cables are not well connected to the speaker. | <ul style="list-style-type: none"> Connect them properly. |
| | | <ul style="list-style-type: none"> The amplifier does not play music. | <ul style="list-style-type: none"> Verify the connectivity and that the music is played through a correct source. |

For spare parts visit the official Gold Note store at:

www.akamaiaudio.it

IMPORTANT SAFETY INFORMATION



CAUTION!
TO REDUCE THE RISK OF ELECTRIC SHOCK, DO NOT REMOVE COVER (OR BACK). NO USER-SERVICEABLE PARTS INSIDE. REFER ONLY TO QUALIFIED GOLD NOTE SERVICE PERSONNEL FOR SERVICE



WARNING!
TO PREVENT FIRE OR SHOCK HAZARD, DO NOT EXPOSE THIS APPLIANCE TO RAIN OR MOISTURE

Do not disassemble any part of the product.

Do not use any part of the product for other purposes.

For service and problems of any kind, contact qualified Gold Note personnel.

Protect the product from rain, humidity and keep away from heat sources, electric and electronic motors etc.

The power Chord supplied must be used only on this unit.

Gold Note does not have responsibility for any improper use of this unit.

This appliance has a serial number located on the rear panel.

Please record the model and serial number and retain them for your records.

Serial Number: _____

Model: _____

IMPORTANT SAFETY INFORMATION

1. Read these instructions and store them.
2. Heed all warnings.
3. Follow the instructions.
4. Do not use this apparatus near water.
5. Clean only with a dry cloth.
6. Do not block the ventilation openings and install in accordance with the manufacturer's instructions.
7. Do not install near heat sources such as radiators, heat registers, stoves or other apparatus (including amplifiers) that produce heat.
8. Do not defeat the safety purpose of the polarised or grounding-type plug: a polarised plug has two blades with one wider than the other.

A grounding type plug has two blades and a third grounding prong. The wide blade or the third prong are provided for your safety.

If the provided plug does not fit into your outlet, consult an electrician for replacement of the obsolete outlet.

9. Protect the power cord from being walked on or pinched particularly at plugs, convenience receptacles, and the point where they exit from the apparatus.
10. Only use attachments/accessories specified by the manufacturer.

11. Use only with the cart, stand, tripod, bracket, or table specified by the manufacturer, or sold with the apparatus.

When a cart is used, use caution when moving the cart/apparatus combination to avoid injury from tip-over.

12. Unplug this apparatus during lightning storms or when unused for long periods of time.

13. Refer all servicing to qualified service personnel only. Servicing is required when the apparatus has been damaged in any way (such as when the power cord or plug is damaged, liquid has been spilled or objects have fallen into the apparatus, the apparatus has been exposed to rain or moisture) and in any case when the apparatus does not operate normally or has been dropped.



 [goldnote_italy](https://www.instagram.com/goldnote_italy)

 [Gold Note Audio](https://www.facebook.com/GoldNoteAudio)

 [Gold Note](https://www.youtube.com/GoldNote)

Akamai S.r.l.
info@goldnote.it
www.goldnote.it